

SUGGESTED GUIDELINES TO ENHANCE POSTER PRESENTATION

Poster sessions can be a valuable means of promoting discussion both within specific disciplines and across widely different research areas. A poster should be able to stand alone. A colleague should be able to determine the purpose, data, and significance of a project simply by looking at and reading the poster.

A clear title with the author's name, affiliation, address, and phone number is desirable, as well as an abstract in large bulletin type. Charts, drawings, and illustrations might well be similar to those one would use for journal articles, or in making slides; however, they should be readable from a distance of several feet. It is best to keep illustrative material simple.

During the poster session, it may be useful for the author to have on hand a tablet of suitable sketch paper as well as felt markers for discussion purposes.

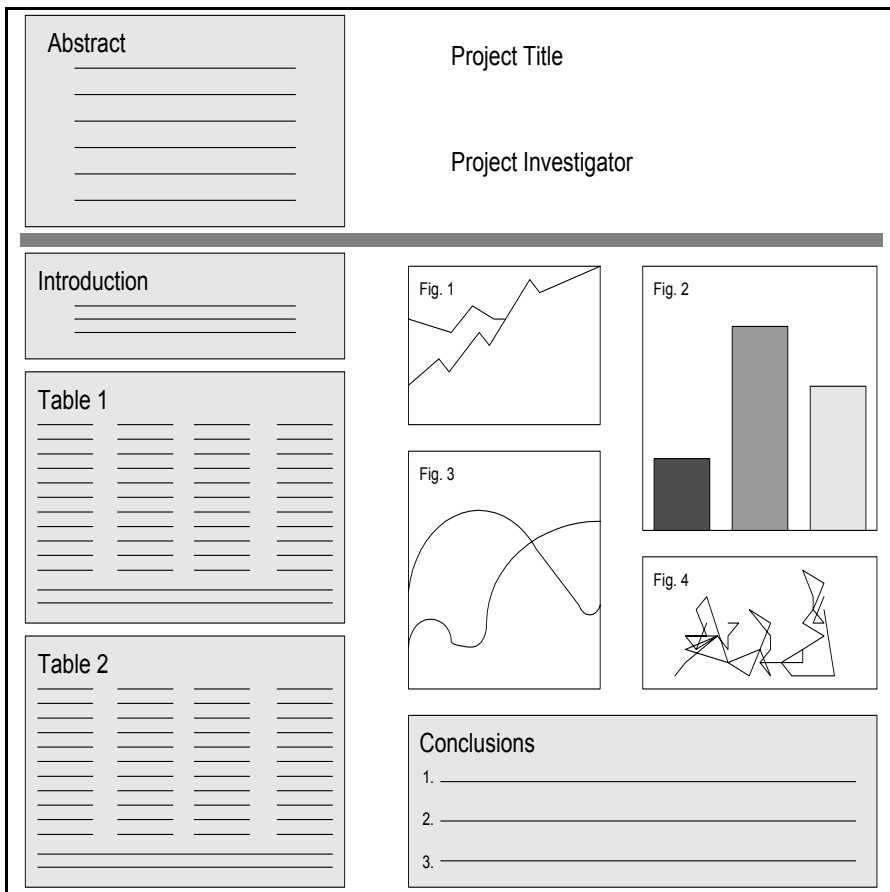

A suggested arrangement of a poster is illustrated below.

- Identify project by title, author name, affiliation, address, and phone number.
- Include an abstract that summarizes the project.
- Include useful figures, tables, schemes, equations, pictures, a pocket for handouts, etc. Text should be kept to a minimum.
- Use contrasting colors.
- Lettering should be a minimum of 24 points (3.5cm) so as to be readable from a distance of several feet.

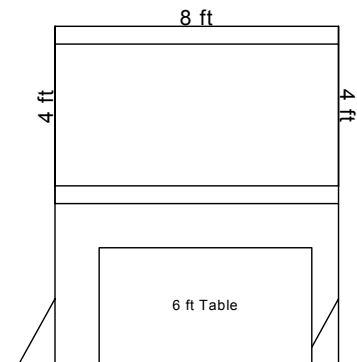

The display areas will have Velcro panels on which the posters will be mounted. **Be sure that your materials are prepared for mounting with Velcro.** Each poster will be set up on a 4' tall x 8' wide bulletin board, which will be provided by SPE, as well as one 6' table.