



2008 SPE Progressing Cavity Pumps Conference SPE EXHIBIT REGULATIONS

SPE has revised these exhibit regulations in order to provide a well-balanced, well-regulated, attractive and successful event. No exceptions to these regulations will be permitted. SPE reserves the right to enforce strict compliance with these Exhibit Regulations.

CHARACTER OF EXHIBIT

The 2008 SPE Progressing Cavity Pumps Conference is undertaken by SPE primarily for the technical education of its members. To provide the best possible atmosphere to discuss the technical application of the equipment and services displayed, each exhibitor agrees as follows:

- To exhibit only products, which it manufactures, represents or distributes, which comprise of materials, equipment, apparatus, systems, services and other component products applicable to system applications, future developments and new technologies.
- No exhibitor shall assign, sublet, or apportion the whole or any part of the space allotted, nor exhibit therein, nor permit any other person or party to exhibit therein, any other goods, apparatus, etc., not manufactured or distributed by the exhibitor in the regular course of business except upon prior written consent of SPE Show Management.
- All exhibits must be manned by at least one company representative during the official Show hours specified by SPE. Exhibit space must be maintained in a neat and orderly manner throughout the exhibition, and no dismantling may begin before the official closing hour on the final day of the exhibition. Failure to do so shall result in forfeiture of Priority Number, if applicable, or loss of right to participate in future SPE exhibitions.. SPE reserves the right to have the exhibit installed at the expense of the exhibitor if work has not commenced or installation completed by the specified SPE deadline in the SPE Exhibit Regulations.
- To refrain from the performance of any act that affects a sale of any of the products or services being displayed or that constitutes a necessary step in effecting such sale. The prohibited acts shall include, but not limited to: (a) the actual sale of products in return for cash, check or other legal tender received at the exhibit; and (b) the execution of contracts or other documents that effect a sale of products or services, whether or not accompanied by receipt of a deposit thereon, for delivery of performance following the Exhibition. Exhibitors may secure names and addresses of persons expressing an interest in the products or services being displayed for the purpose of contacting such person after the Exhibition.
- In deference to fellow exhibitors and to the professional people who constitute the exhibit audience, exhibitors are specifically prohibited from employing any carnival type attraction, animal or human, or from operating such noise creating devices as bells, horns, or megaphones. Sound or music within a booth is permitted, but must be controlled to a reasonable level, and must not be projected outside the confines of the exhibit booth. Exhibitors are responsible for obtaining all necessary licenses and permits to use music, photographs or other copyrighted material in the exhibitor's booth or display. Costumed personnel must be appropriately clad and must remain within the exhibitor's booth space except when necessarily arriving and leaving the booth or exhibition area.
- Arrangements for all food and beverages must be purchased through the Official Caterer. Beverages include alcoholic beverages, soft drinks, coffee, bottled water, etc. Exhibitors found in violation of this ruling are subject to corkage fees established by the Official Caterer and/or may lose their right to participate in future SPE exhibitions.
- Regarding consumption of alcohol at official SPE events, SPE encourages everyone to act responsibly and do not drink and drive.



2008 SPE Progressing Cavity Pumps Conference SPE EXHIBIT REGULATIONS

- Samples, souvenirs and advertising material may be distributed by the exhibitor only from within their booth. Balloons (including helium) and stickers are prohibited in the facility. (Handouts with gummed backing that adhere or cause adhesion are considered stickers.)
- Equipment must be arranged so that show visitors do not stand in the aisle while examining equipment or watching demonstrations. Strolling entertainment or moving advertisements outside of an exhibitor's exhibit space is prohibited. Demonstration areas should not be placed on the aisle line of the exhibit. Normal aisle traffic cannot be blocked at any time.
- SPE Show Management is sensitive to the time, effort and cost related to the success of the conference by exhibitors, and therefore, expressly forbids the solicitation of goods and services, distribution of literature, promotional items or souvenirs by anyone other than registered exhibitors. Exhibitors witnessing this type of situation should notify their SPE Floor Manager.
- **Exhibitors hosting hospitality functions (whether on-site or off-site) are prohibited from holding those activities during official Show hours or official show events.**
 - Only exhibitors in good standing are permitted to host a hospitality function in an official Show hotel. (All requests for a hospitality suite or public function space must be made through SPE).
 - Any exhibitor conducting a function in direct competition with official show hours or official show events will forfeit their priority number, if applicable, and/or be subject to the loss of right to participate in future SPE exhibitions. If the event in violation of this policy is cancelled, the exhibitor is responsible for all financial obligations associated with this event.
 - Any exhibitor's division and/or subsidiary not contracted for exhibit space in the event conducting a function in direct competition with official show hours or official show events will force the loss of the exhibitor's priority number, if applicable, and the right of the exhibitor to obtain a hospitality suite and/or function space during official show days the following year.
 - If an exhibitor should cancel or not occupy the exhibit space during official show hours, SPE reserves the right to notify the hotel to cancel any hospitality space and/or hotel guest rooms under that company's name. Exhibitor shall remain liable for the payments made to the hotel.
- Exhibitor shall abide by and observe all federal, state and local laws, codes, ordinances, rules and regulations, and all rules and regulations of the facility (including any union labor work rules). Without limiting the foregoing, Exhibitor shall construct its exhibit to comply with the Americans with Disabilities Act.
- **The use of roller skates, roller blades and/or motorized or manually operated scooters (including segways) is strictly prohibited in the facility at all times. Only current ADA approved equipment will be authorized.**
- Each Exhibitor understands and agrees that the Exhibit Regulations are an integral and binding part of the Application/Contract for Exhibit Space.



2008 SPE Progressing Cavity Pumps Conference SPE EXHIBIT REGULATIONS

BOOTH DISPLAY TYPES

Linear Booth

A standard/linear booth (10'x10') is any booth that shares a common back wall and adjoins other exhibits on one or two sides.

The maximum back wall height is eight-feet three inches (8'3") and is allowed only in the rear half of the booth space.

A four-foot (4') height restriction is imposed on all materials in the remaining space forward to the aisle.

Hanging signs/graphics are **NOT** permitted over standard/linear booths.

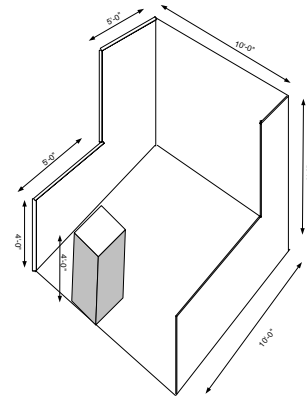

Perimeter Booth

A Perimeter Booth (10'x10') is a standard/linear booth located on the perimeter walls of the exhibit floor.

The maximum back wall height is twelve feet (12') and is allowed only in the rear half of the booth space.

A four-foot (4') height restriction is imposed on all materials in the remaining space forward to the aisle.

Hanging signs/graphics are **NOT** permitted over standard/linear perimeter booths.

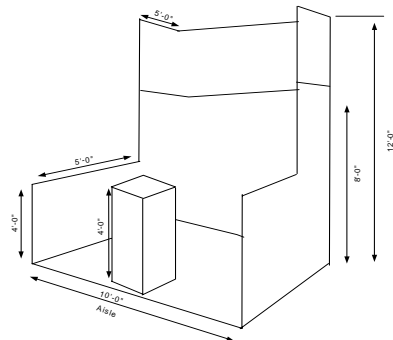

Peninsula Booth

A peninsula booth is any exhibit 20'x20' or larger with a depth from the common back wall to the aisle of at least 20' and with aisles on three (3) sides.

Where two (2) peninsula booths share a common back wall (also known as Split Island Booths), **the maximum height is 16 feet in all areas of the booth, including the back wall.**

An 8-foot drape is supplied to separate booths. The portion of the booth from the 8-foot drape to the maximum booth height of 16 feet must be finished.

Hanging signs/graphics are **NOT** permitted over peninsula and/or split island booths.

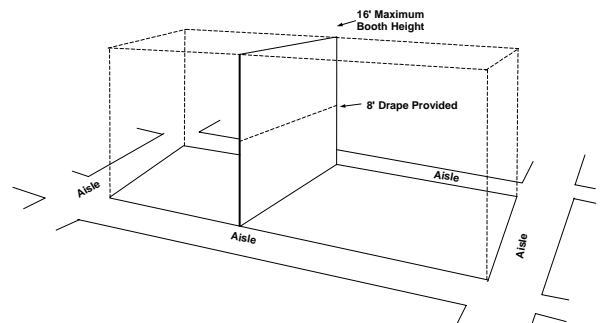



2008 SPE Progressing Cavity Pumps Conference SPE EXHIBIT REGULATIONS

Walk-Thru Booths

A Walk Thru Booth is any booth 20'x20' or larger that backs up to another walk-through or peninsula booth.

The maximum height of a Walk Thru Booth is 16 feet.

An 8-foot drape is supplied to separate booths. The portion of the booth from the 8-foot drape to the maximum booth height of 16 feet must be finished.

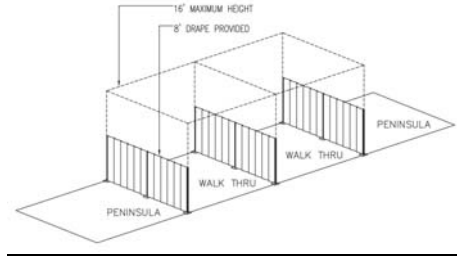

Hanging signs/graphics are **NOT** permitted over walk thru booths. All signage and/or graphics within the booth may not extend above the 16' maximum height allowance.

Island Booth

An Island Booth is any exhibit 20'x20' or larger and is surrounded by aisles on four sides.

The maximum height of an island booth is 25 feet in all areas of the booth. Certain physical limitations may prohibit the maximum 25-foot booth height. Exhibitors should refer to the floor plan to specific height limitations.

Exceptions to the 25-foot maximum booth height may be extended to physical equipment that exceeds the maximum height restrictions. This does not include the physical exhibit structure. Exceptions are at the discretion of SPE.

Hanging signs/graphics are permitted over island booths.

The maximum height of hanging signs/graphics is 25 feet to the top of the sign/graphic.

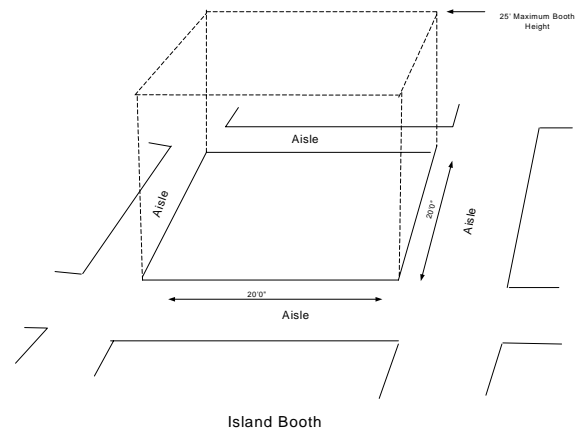

Multi-Level Booths

All multi-level (double-decker) booths require certification by a registered engineer and floor plans must be submitted to SPE Show Management to obtain Fire Marshal approval.

Construction of multi-level booths must conform to all applicable local codes regarding access, egress and fire safety equipment.

For questions regarding the design of your multi-level design, please forward renderings to the SPE Exhibits Manager.



2008 SPE Progressing Cavity Pumps Conference SPE EXHIBIT REGULATIONS

HANGING SIGNS & GRAPHICS GUIDELINES

- **Hanging signs and graphics are permitted in island booths with dimensions of 20'x20' or larger.**
- **Hanging signs and graphics are NOT permitted in peninsula, split island, walk thru or standard/linear booths.**
- **The maximum allowable height for hanging signs and graphics is 25 feet measured from the floor to the top of the sign.**
- **Certain physical limitations of the facility may prohibit the maximum 25-foot allowable height. Exhibitors should refer to the floor plan to specific height limitations. The maximum allowable height of hanging signs and graphics is also dependent on the ceiling load limits.**
- **Exhibitors are responsible for notifying SPE and/or the Official Contractor if they are planning on hanging signs or graphics in their exhibit booth design. Exhibitors must send this written notification. If written notification is not received, SPE and/or the Official Contractor cannot guarantee the hanging of the sign or graphic. Exhibitors will not be granted an extension to the published move in schedule for delays caused by the installation of hanging signs or graphics.**
- All hanging signs and graphics must be located at least three (3) feet from the perimeter boundary of the booth. Any lighting associated with a hanging sign must be integral to the sign and no spotlighting is allowed.
- All sides of hanging signs and graphics must be covered or finished in such a manner as not to detract from those booths behind it. All hanging signs and graphics, regardless of size, should be constructed of lightweight flameproof materials.
- Any signage extending higher than the external booth wall and visible to those viewing booths in the aisles behind it must remain stationary with the rear of the sign covered and/or finished in such a manner as not to detract from those booths behind it. All materials must be contained within the contracted booth space.
- The facility regulations state that no signs will be allowed to hang from any electrical fixtures, raceways, water/gas/air/fire protection piping, supports or hangers. Permanent facility graphics, signs or displays may not be blocked in any manner.
- All overhead hanging must be assembled, installed, removed and disassembled by the Official Contractor. Exhibitors, display companies and/or I&D representatives may supervise their respective rigging activities, but will not be allowed to assemble/disassemble or install/remove rigging.
- All rigging must conform to show rules, regulations and facility limitations. Hanging anchor points must be pre-fabricated and ready to use. If any hang point supports over 250 pounds, exhibitor must notify the Official Contractor immediately for special authorization.
- For hanging signs and graphics, other than banners, exhibitor must submit a blueprint or drawing to the Official Contractor with detailed information in order for hanging anchor points to be determined. Electrical signs must be in working order and in accordance with the National Electrical Code. Electrical Service requirements must be ordered in advance through the Official Electrical Contractor.
- Exhibitor is responsible for providing the Official Contractor with a placement diagram of the hanging sign including the number of feet from each side of the exhibit space that the sign is to be placed. The ceiling structure and relation to the support beams may require an exhibitor's sign to be moved from the requested location.



2008 SPE Progressing Cavity Pumps Conference SPE EXHIBIT REGULATIONS

- Exhibitor is also responsible for providing the Official Contractor with the Type of Sign (cloth, metal, wood, other), Shape (square, triangle, rectangle, other), Size (height, length, width), and Weight.
- Overhead hanging signs are to be sent in separate containers directly to the Official Contractor. All containers must arrive no later than one week prior to the first exhibitor move-in day. Should an exhibitor not arrange for an advance shipment of the hanging signs, exhibitor must notify the Official Contractor. If these procedures are not followed, SPE and the Official Contractor cannot guarantee the hanging of the sign. Exhibitors will not be granted an extension to the published move-in schedule for the delays caused by the installation of hanging signs.
- All hanging signs are subject to SPE inspection and may require on-site modification.

EXHIBIT BOOTH DISPLAY REGULATIONS

- Any portion of a display that extends above or beyond that of the booth adjoining to the rear or side must be finished with paint or drape at the exhibitor's expense. Any portion of your booth facing an aisle must be finished.
- The penetration of floors, walls, ceilings, or trim will not be permitted; neither may any holes be drilled in any portion of the facility. Displays must be freestanding and not rely on any part of the Exhibit Hall other than the floor for support.
- If a booth design includes special lighting, all lighting, fixtures, or trusses should remain within the boundaries of the exhibit space. Special effects lighting must not project onto other exhibits or show aisles and should be directed to the inner confines of the exhibit space. All special lighting effects should be in good taste and not interfere with neighboring exhibitors or otherwise distract from the professional atmosphere of SPE. All special lighting fixtures must be constructed of noncombustible or effectively treated with an approved fire retardant chemical.
- The use of carpeting or other professional floor covering is required by each exhibitor. These floor coverings must not be sealed to the floors in such a manner as to injure the floor or be so installed as to be a hazard to public safety or as to endanger the public. Exhibitors are responsible for the final condition of the floor in their space. The edges of raised flooring may be inclined, providing the slope is gradual and gentle. Exhibitors are urged to simplify access for disabled persons by providing a ramp of at least 3.5 feet wide set in place at right angles to the aisle.
- No exhibitor shall in any manner obstruct an exit, aisle, restroom or easement at any time. In all cases, exits and fire connections must be clearly identifiable. The Fire Marshal shall have the final ruling on this matter.
- Designated "NO FREIGHT" aisles must be maintained clear of crates and exhibit materials during move-in and move-out. These aisles are required for emergency access throughout the exhibit area and to expedite freight and empty crate moving.
- All exhibit displays should be designed and erected in a manner that will withstand normal contact or vibration caused by neighboring exhibitors, hall laborers or installation/dismantling equipment such as forklifts. Displays should also be able to withstand moderate wind effects that may occur in the exhibit area when freight doors are open. Exhibitors should refer to local building codes that regulate temporary structures.
- Exhibitors should ensure that any display fixtures such as tables, racks or shelves are designed and installed properly to support the product or marketing materials to be displayed upon them.



2008 SPE Progressing Cavity Pumps Conference SPE EXHIBIT REGULATIONS

- Drip pans and scrap buckets should be provided for operating machinery to prevent lubricants, paints, etc., from staining the floor causing a slippage hazard.
- Paint must be removed nightly and all cans must be tightly closed to prevent their contents from staining the floor, causing a slippage hazard, and tracking of paint, etc., over other exhibitor's carpet.
- Column or wall outlets *may not* be used in the facility for direct connection by *anyone* other than employees of the Official Electrical Contractor.
- Exhibit displays are subject to inspection by SPE and may require modification to meet safety standards. SPE reserves the right to remove any exhibit, at the exhibitor's expense, if the display does not meet the specifications set forth in the Exhibit Regulations.
- **BOOTH DRAPING (MASKING):** SPE Show policy requires covering (finished and/or draping) on each side of the booth, of a corner location, if materials are stored behind the display or if grid work and/or electrical cords are exposed to public viewing. Exposed parts of displays (including backs) must be completely finished so that they are not objectionable to other exhibitors, delegates or SPE Management and are in keeping with the professional appearance of the exhibit area. Any booth draping (masking) required for either or both sides (or back) of a booth will be ordered from the Official Contractor at the expense of the exhibitor.
- **NOISE LEVELS:** Mechanical reproduction of sound or music relating to an exhibit, or noise generated by production demonstrations shall be kept at a sufficiently low volume so as not to project beyond the confines of the exhibitor's booth and should not disrupt the activities of the neighboring exhibitors. Speakers and other sound devices should be positioned so as to direct sound into the booth rather than the aisles. SPE reserves the right to impose limitation on noise levels and any method of operation, which becomes objectionable.
- **DISTRIBUTION OF PUBLICATIONS:** Publications/brochures may only be distributed from your booth. No distribution is permitted from the aisles of the exhibit area, the registration area, or anywhere in the facility. Publication Cubicles may be rented by companies for their industry related publications. Brochures other than those assigned to the company renting the cubicle will be removed and destroyed.
- **SECURITY:** SPE will provide appropriate security in order to ensure the safety of its attendees and exhibitors. SPE assumes no responsibility for loss, damage or theft incurred to any exhibit or property of the exhibitor. SPE recommends that exhibitors consider the benefit of securing individual security guards for the exhibit. Exhibitor booth security may be ordered through the official Security Company. Unauthorized persons will not be permitted to enter or remain the exhibit area after closing hours; however, certain authorized persons may have access to the exhibit area at any time.
- **INSURANCE:** Insurance for fire, public liability and theft must be taken out by each exhibitor at its own expense. The insurance is to cover the full period of occupancy of the premises by the exhibitor, its agents and employees.
- **CLEANING AND DISPOSAL OF USED/EXCESS MATERIALS:** Each exhibitor must keep its exhibit clean and properly dispose of all refuse. All used or leftover materials resulting from delivery, installation and removal activities of the exhibitor shall be disposed of at the exhibitor's expense. In addition, exhibitors are responsible for the removal and disposal of carpeting, padding, and/or professional flooring utilized in their space. Should any of these items remain within the exhibit space after dismantling, these items will be disposed of at the exhibitor's expense.
- **STORAGE:** Fire regulations in most exhibit facilities prohibit storing product, literature, empty packing containers or packing materials behind back drapes or under draped tables. In most cases, however,



2008 SPE Progressing Cavity Pumps Conference SPE EXHIBIT REGULATIONS

exhibitors may store a limited supply of literature or product appropriately within the booth area, so long as these items do not impede access to utility services, create a safety problem or look unsightly.

• **INSTALLATION AND DISMANTLING SCHEDULES**

- Exhibits must comply with the published installation and dismantling schedules and procedures as outlined in the Exhibitor Services Manual. Requests for alterations to these schedules must be submitted to SPE in writing for approval.
- **Early Tear-Down:** Should an exhibitor begin to dismantle, pack any part of the exhibit, or vacate their exhibit space before the official close of the show, the exhibitor shall forfeit their priority number, if applicable, and/or be subject to the loss of their right to participate in future SPE exhibitions. Exhibitors should contact SPE Show Management in the event further discussion is needed.

• **BOOTH INSPECTION DEADLINE (NO-SHOW RULING)**

- **The installation of all exhibits must be complete by 17:00 on Sunday, 27 April. No installation will be allowed after 17:00.**
- **Exhibitors must submit written requests for installations that will not begin until after 17:00 on Sunday, 27 April for SPE Show Management approval. Approval of late installation requests is at the discretion of SPE.**
- **Should an exhibit space remain vacant after 17:00 on Sunday, 27 April and arrangements for exhibit services (carpet, electricity, freight delivery, etc.) have been ordered and verified, SPE will assume the exhibitor will be late, but will arrive.**
- **Should an exhibit space remain vacant after 17:00 on Sunday, 27 April, with no arrangements for exhibit services ordered, and SPE has not been notified of a late installation, SPE will make this area into a carpeted lounge or otherwise reassigned by SPE.** Should an exhibitor arrive after the following steps have been taken, the exhibitor will be responsible for costs incurred by SPE. SPE also reserves the right to resell the cancelled space and the contract will become null and void. There will be no refunds due to an exhibitor who fails to utilize their contracted space and the exhibitor will remain responsible for any outstanding balances due.

FIRE REGULATIONS

The regulations of the City Fire Department must be followed, and all exhibits may be subject to Fire Department inspection.

- All decorative materials including drapes, signs, banners, acoustical treatments, table coverings, etc., must be noncombustible or effectively treated with an approved fire retardant chemical.
- All canopies, ceilings, or other overhead construction for booths or exhibits must be of non-combustible materials.
- Display and/or operation of any heavy equipment must be subject to the floor loading limits of the exhibit area.
- Any special effects, decorations, displays, or operating equipment of any kind of questionable nature must be approved before being installed.
- The use of any flammable liquids, gases or solids and the use of compressed gases are not permitted.



2008 SPE Progressing Cavity Pumps Conference SPE EXHIBIT REGULATIONS

- The exhibiting of motorized vehicles or other equipment involving the use of flammable liquids shall be subject to specific regulations. Gas tanks must not contain more than ¼ tank of fuel and must be sealed, locked, and all battery cables must be disconnected. Ignition keys must be removed and at display location.
- Heat-producing appliances employing open flames, high heat, lighting effects, etc., as part of an exhibit shall not be operated unless special approval has been obtained.
- All operating electrical, plumbing and heating devices shall be installed in compliance with the requirements of the City Municipal Code. The required permits shall be obtained before such installations are made, and all installations shall meet with the approval of the inspecting authority.
- Fire hose reels and cabinets must be readily accessible and cannot be obstructed in any manner whatsoever.

COPYRIGHT REGULATIONS

Exhibiting companies shall not display, perform, or otherwise reproduce any Copyrighted Work of another without the express written consent of the copyright owner. The term "Copyrighted Work" includes literary works, musical compositions and performances, phonographs, audiotapes, videotapes, motion pictures, photographs, graphics, and all other works for which U.S. Copyright Law affords protection. More specifically, Exhibitor shall not display, perform, or otherwise reproduce, or cause to permit to be displayed, performed, or otherwise reproduced, any copyrighted musical composition or performance of another at the Exhibition without the copyright owner's express written consent. This includes the reproduction of any radio or television broadcasts, audiotapes, videotapes, and/or motion pictures that include, in whole or in part, the music composition(s) of any other party.

EXHIBITOR SERVICES

Official Service Contractors

To ensure the continuation of a smooth installation, dismantling and operation during the Exhibition, Official Contractors have been appointed. Although full-time employees of exhibitor-appointed contractors, other than the Official Contractors, may be authorized to gain access to exhibition areas, exhibitors are urged to obtain required labor and services from SPE Official Contractors. Complete details of official contractors are provided within the Exhibitor Services Manual.

Exclusive Contracted Services

The services listed below must be provided by the **Exclusive SPE Contractor**. No other company will be given permission for the performance of these services:

- Electrical, Internet, Telephone, A/v – Intercontinental Hotel Houston
- Drayage/Forklift Operations - Freeman
- Rigging – Overhead or Genie Lift - Freeman

REVISED 2008: Exhibitor-Appointed Contractors

An Exhibitor-Appointed Contractor (EAC) is any person or company other than the designated "official" or "exclusive" contractors that provides a service (supervision, display installation and dismantling, advertising agencies, models, florists, photographers, aquarium supply firms, computer firms, audiovisual firms, etc.) and requires access to the exhibit hall any time during installation or dismantling or show dates.



2008 SPE Progressing Cavity Pumps Conference SPE EXHIBIT REGULATIONS

REVISED 2008: Exhibitor Responsibilities

- Exhibiting companies are responsible for advising SPE of their hired Exhibitor-Appointed Contractors' company name, contact information, and a description of the service(s) the EAC will be providing for the exhibiting company.
- Exhibiting company must complete and submit the **Work Authorization Request Form** no later than **17 March 2008**.
- Exhibitors are not permitted to obtain official SPE Exhibitor Badges for their appointed EAC personnel. SPE Exhibitor Badges are for exhibiting companies only.
- Exhibitors are ultimately responsible for each of their EAC's with regards to their services provided, adherence to all SPE Exhibit Regulations, union regulations, financial responsibilities for services acquired through SPE Official and Exclusive Contractors, and violations and/or damages that may occur.

REVISED 2008: Exhibitor-Appointed Contractor Responsibilities

- Exhibitor-Appointed Contractors (EAC) are required to meet specific criteria before they will be permitted access to the exhibition area. Upon receipt of the Work Authorization Notification Form, SPE will provide each EAC with a packet of important information regarding the EAC Program. Each EAC must complete all information and no exceptions to this program will be authorized.
- Each EAC must complete and return the SPE **Exhibitor-Appointed Contractor Agreement** and submit to SPE by **31 March 2008**.
- Each EAC (not exhibiting companies) must submit certificates of insurance for Commercial General Liability Insurance, Business Automobile Liability Insurance and Worker's Compensation Insurance.
 - Commercial General Liability coverage must provide \$1,000,000 Combined Single Limit each Occurrence and \$2,000,000 General Aggregate and \$1,000,000 Products/Completed Operations Aggregate. Commercial General Liability must include Product/Completed Operations and Broad Form Commercial General Liability with ***NO EXCLUSIONS***.
 - Business Automobile Liability must include all owned, non-owned and hired vehicles with limits of \$1,000,000 Combined Single Limit Bodily Injury and Property Damage Liability.
 - The Worker's Compensation and Employers' Liability Insurance must provide a minimum limit of \$500,000 each Accident; \$1,000,000 Disease - Policy Limit; \$500,000 Disease - each Employee and meet the Statutory Requirements established by the State of Texas.
 - Umbrella Liability is acceptable to meet above minimum requirements.
 - Alert the insurance carrier that the "Certificate Holder" is the "Society of Petroleum Engineers.", 222 Palisades Creek Drive, Richardson, TX 75080, U.S.A., +1.972.952.9494. Deadline **31 March 2008**.
- EAC's must provide the name(s) of their key on-site personnel by **31 March 2008**. SPE will prepare a name badge for the EAC's key on-site personnel, which will be available for pick-up at Registration located in the Exhibitor Registration area in the lobby outside of the Exhibit Hall and which allows the same access as an exhibitor badge. For security reasons, do not have an Exhibitor Badge made for your EACs. All other EAC personnel (non key on-site personnel) must wear a wristband provided by SPE, which allows access only during installation and dismantling.

Failure to meet specified EAC Program criteria will jeopardize the EAC's ability to obtain work authorization from SPE now and in the future.



2008 SPE Progressing Cavity Pumps Conference SPE EXHIBIT REGULATIONS

REVISED 2008: Rules and Regulations Governing Exhibitor-Appointed Contractors

- EAC's will be denied access to the exhibit floor without current proof of insurance coverage in all of the above mentioned categories.
- Any EAC found working on the show floor without SPE Management authorization will be escorted from the premises and not allowed back on the exhibit floor.
- EAC's will refrain from placing an undue burden on the Official Contractors, especially by not interfering in any way with the Official Contractor's work.
- EAC's will **NOT** solicit business on the show floor at any time, including installation, during the show, and dismantling.
- EAC's will cooperate fully with Show Management and the Official/Exclusive Contractors and will comply with existing union rules and regulations as outlined in the Exhibitor Services Manual.
- Cameras or photography are prohibited on the exhibit floor without permission from Show Management. With approval, EAC's may photograph only the booth(s) with which they have contractual arrangements.
- While aisle carpeting is being installed, jockey boxes, ladders and the EAC's equipment must be removed completely from the show floor, be placed inside the booth being installed, or removed from the exhibit hall.
- EAC's are **NOT** allowed on the show floor during installation and dismantling without either an SPE-issued wristband or official SPE conference badge. SPE wristbands and official SPE conference badges are non transferable and must be worn at all times. SPE Wristbands are not valid during show days.
- EAC's are **NOT** authorized to have SPE Exhibitor badges.

REVISED 2008: SPE Show Management's Discretionary Rights

SPE Show Management reserves the right, at its sole discretion, to withhold approval or to dismiss from the event, any service contractor whose participation in the event may, in the opinion of SPE, lead to strikes, picketing, or other labor action directed at the event, or other disruptions of the event, or other reasonable interference with or inconvenience to the event or any exhibitors.

Failure to meet any one of the above steps could jeopardize the Exhibitor-Appointed Contractor's ability to obtain work authorization.

- **Please note:** An exhibitor may utilize all or a combination of any of these three sources for exhibit installation and dismantling; however, only authorized personnel will be granted access to the exhibition area. To request authorization for your EAC(s), exhibitors must submit the **Work Authorization Request Form** to SPE by **17 March 2008**.

Please note: An exhibitor may utilize all or a combination of any of these three sources for exhibit installation and dismantling; however, only authorized personnel will be granted access to the exhibition area.

GOOD NEIGHBOR POLICY

Any exhibitor using audio or video content in their booth for the purpose of demonstrating equipment or services agrees that such content shall be appropriate for a general audience, and agrees to refrain from using content that may be considered offensive to such an audience. In the event of a complaint from any person regarding the content or noise level by an exhibitor, SPE will investigate the complaint. Should SPE determine the content to be offensive or in excess of appropriate noise levels, exhibitor agrees to cease using such content or noise making



2008 SPE Progressing Cavity Pumps Conference SPE EXHIBIT REGULATIONS

device. Repeated violations of this policy can, at SPE's discretion, result in expulsion from the show and/or loss of earned priority points.

PHOTOGRAPHY REGULATIONS

No commercial photographer will be admitted to the exhibits unless special arrangements have been made with SPE Show Management by submitting notification of intent to use an exhibitor appointed contractor. Should an exhibitor witness someone taking photographs of their booth and/or equipment without permission, the exhibitor is responsible for discussing this matter with the person taking the photographs. Should the situation continue, the exhibitor should contact SPE Show Management for assistance.

MARKET RESEARCH AND SURVEYS

Any Exhibitor wishing to contact market research or surveys during the Conference must adhere to the following procedures. Surveys and questionnaires must be submitted for approval to the SPE Exhibits Manager no later than sixty (60) days prior to the event.

All surveys/questionnaires must be conducted within the confines of the exhibitor's booth. At no time may exhibit personnel leave their booth to encourage participation or to survey/question attendees.

Market research companies must identify the names of the clients for whom they are conducting research. Survey documents and any publication or results may not include the name of the Conference or make any reference to the event which might cause respondents or readers to believe that SPE is endorsing, approving, or involved with the research. Exhibitors who violate these guidelines may jeopardize their earned priority points and future participation in SPE.

AGE RESTRICTIONS TO EXHIBIT AREA

No one under the age of 18 is permitted in the Exhibit Area during move-in or move-out.

No one under the age of 15 is permitted in the Exhibit Area during official show hours.

AFTER HOURS WORK PERMITS

SPE recognizes that, in critical situations, it may be necessary for an exhibitor to work beyond the published installation and dismantle scheduled hours. Authorization to work late will be based on the type of work to be done, and the number of people needing access to the facility. Exhibitors should obtain approval from their Floor Manager. For authorization to work late, you must be able to demonstrate that construction of your exhibit cannot be completed during scheduled hours. For safety and security reasons, work late authorizations will be granted only when conditions impact a company's ability to complete construction of their exhibit by the published deadline.

PARKING

Any vehicle parked in designated no parking zones or designated fire lanes will be towed to a location designated by the facility at the owner's expense.

SMOKING POLICY

The majority of facilities are designated as non-smoking facilities. Exhibitors are responsible to abide by the facility smoking policy.



2008 SPE Progressing Cavity Pumps Conference SPE EXHIBIT REGULATIONS

AMERICANS WITH DISABILITIES ACT

Exhibitor agrees to comply with the laws and regulations set forth for public accommodation by the Americans With Disabilities Act ("ADA") and applicable state and local law. Exhibitor further agrees and warrants that any exhibit booth, display, or other contrivance placed in the exhibit space licensed to the Exhibitor by SPE shall at all times comply with ADA and applicable state and local law, including accessibility, usability and configuration. Exhibitor further agrees to fully indemnify and hold SPE harmless from any and all claims or actions brought against SPE as a result of Exhibitor being in violation of the ADA, its regulations, or applicable state or local law during the period of this contract, including the amount of any claim or judgment SPE is compelled to pay, and the costs, including attorneys fees incurred by it in defending against all such claims. SPE reserves the right to revoke this contract without penalty if it determines that Exhibitor is in violation of the ADA or applicable state or local law with respect to any exhibit booth, display or other contrivance placed in the space licensed to Exhibitor under this Contract.

AMENDMENTS

Any and all matters and questions not specifically covered by these exhibit regulations shall be subject to the decision of SPE and may be amended at any time by SPE in the interest of the Exhibition and notice thereof shall be binding on the exhibitors equally with the foregoing in these exhibit regulations.

Inquiries regarding the SPE Exhibit Regulations should be directed to:

**SOCIETY OF PETROLEUM ENGINEERS
MEETINGS & EXHIBITS DEPARTMENT
222 Palisades Creek Drive
Richardson, Texas 75080 U.S.A.**

Telephone: +1.972.952.9393

Facsimile: +1.972.952.9435

**For complete information on the
SPE Progressing Cavity Pumps Conference,
please visit our website at www.spe.org.**